

IBARMIA.

ZVH EXTREME

55 / 58

TECHNICAL SPECIFICATIONS

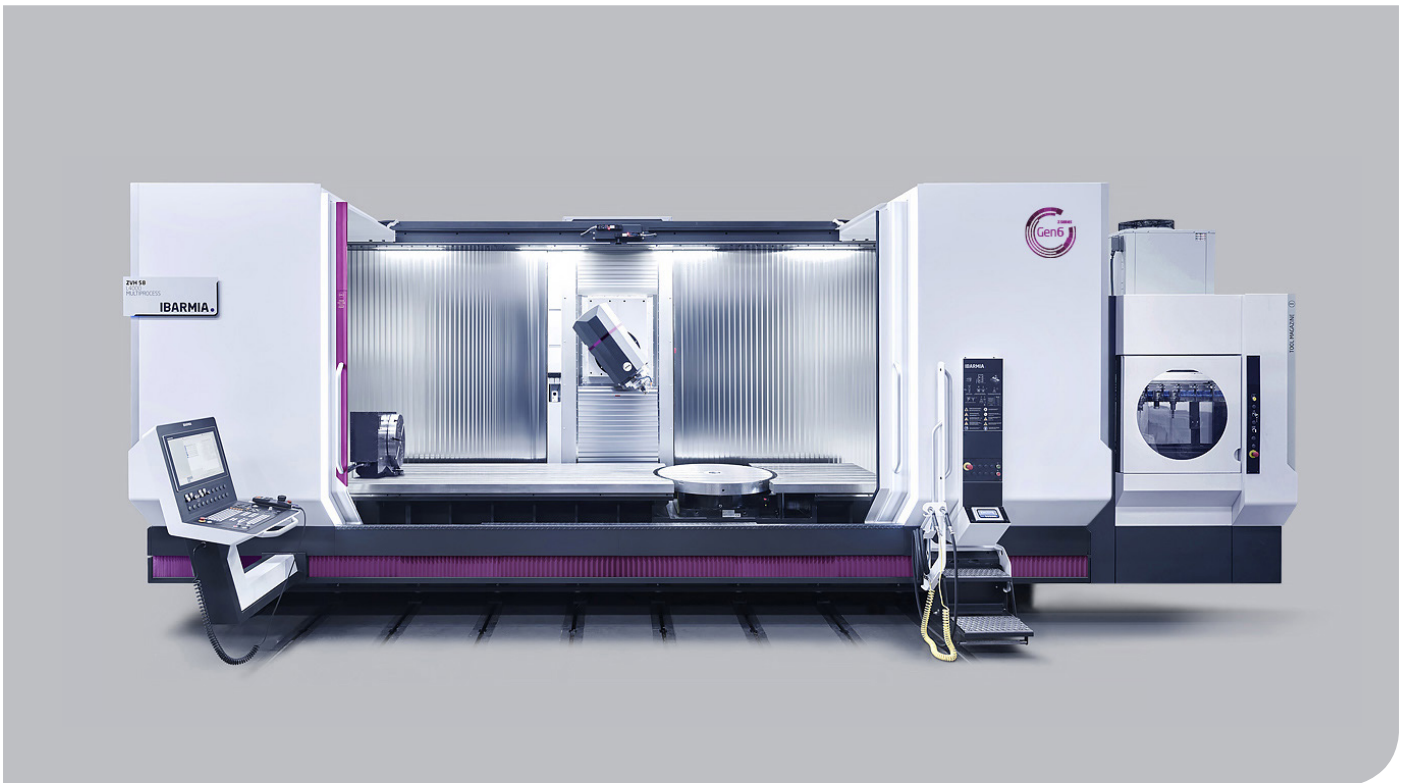

ZVH EXTREME

Combine 5 axis vertical and/or horizontal machining capacity with a fixed table so you can be ready for any job at the shortest notice.



Z SERIES

ZVH EXTREME**ZVH 55****ZVH 58****TRAVELS**

-X axis travel (length)	mm	2200 - 12.000	
-X axis travel working in 2 areas (vertical)	mm	2x 465 (L2200) - 2x 2665 (L6000)	
-Y axis travel (cross)	mm	800	1000
-Z axis travel (vertical)	mm	1100	
-B axis head range	°	+/-115	
-Maximum swing diameter (C axis integrated rotary table)	mm	1200	1400

TABLE

-Fixed table dimensions	mm	L2200: X+400 mm; <L3000: X+600 mm & Y +50 mm	
-Maximum table load capacity	Kg/m ²	2000	
-Number of "T" slots		5	7
-"T" slots size	mm	18 H7	
-Distance between "T" slots	mm	125	
-Min. / Max. distance spindle nose / table	mm	V (0----1100) - H (375----11475)	
-Table height	mm	1025	

TILTINH HEAD

-Turning torque	Nm	800	
-Position clamping force	Nm	6000	

MAIN SPINDLE

-Spindle taper		Standard: SK 50 - Optional: HSK A-100 / SK 40	
-Maximum speed	rpm	Standard: 8000 - Option: 12.000	
-Maximum power	kW	Standard: 43 - Option: 46 / 84	
-Maximum torque	Nm	Standard: 260 - Option: 200 / 452	

CONTROLS

-Available digital controls		Fanuc / Heidenhain / Siemens	
-----------------------------	--	------------------------------	--

FEED

-Feed thrust X-Y-Z 100% (S3 40%)	N	X: 15.021 (22.971) / Y: 12.154 (17.255) / Z: 10.649 (15.529)	
-Rapid feed for positioning X-Y-Z	m/min	45	
-Maximum working feed X-Y-Z	m/min	30	
-Rapid feed for positioning in B axis	rpm	50	

ACCURACY VDI / DGQ3441

-Positioning accuracy Tp X-Y-Z (1000 mm)	µm	10	
-Repeatability	µm	5	
-Measuring system on B axis		Rotary scale	
-Positioning accuracy Tp B • C axes	s	+/-5 • +/-4	

ZVH EXTREME**ZVH 55****ZVH 58****CAPACITIES**

-Milling capacity in steel St 60	cm ³ /min	1100
-Drilling capacity in steel St 60	Ø mm	70
-Tapping de roscado en acero St 60	mm	M45

TOOL MAGAZINE

-Number of tools		50. Optional: 100, 150, 255
-Maximum tool length	mm	400
-Maximum tool weight	Kg	20
-Maximum tool Ø with full magazine	mm	Ø125
-Maximum tool Ø with free spaces	mm	Ø200
-Tool changing time	s	10
-Chip to chip time	s	12

GENERAL

-Machine painted in 3 colours	RAL	White 9010, Ligth Grey 9006, Dark Grey 7021
-Total power installed	kW	60
-Power connection voltage	V	400 V / 50 Hz
-Required compressed air pressure	bar	6
-Machine length (L2200 / L6000)	mm	5850 (L2200) - 11650 (L6000)
-Aproximate net weight (L2200 / L6000)	kg	19.000 / 34.500 22.000 / 38.500

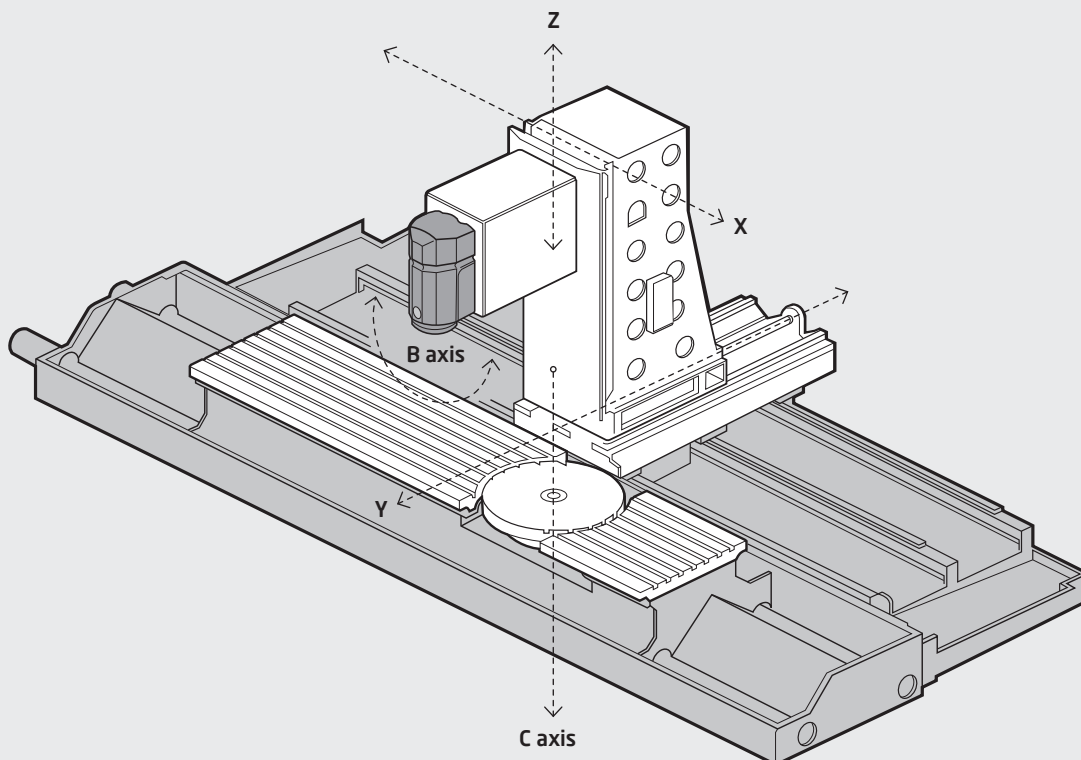

INCLUDED ITEMS IN STANDARD CONFIGURATION

- 5 axis model: longitudinal X, transversal Y, vertical Z, tilting head B, combined with C and/or A axis rotary table.
- Direct measuring on linear axes X / Y / Z.
- Measuring by rotary scale on rotary axes B / C / A.
- Travelling on lineal guides and ball screws.
- Servomotors with braking system for the axes.
- Rack and pinion system on machines from 6000 mm long.
- Hydraulic counter weight for the head.
- Electrospindle thermal compensation.
- 30 tool ATC magazine.
- Air blast for tool cleaning.
- Totally encapsulated working area.
- Vertical covers on X axis (steel bellows).
- Safety windows.
- Illumination of working area.
- Double auger system for chip evacuation.
- Removable lateral pannels.
- Moving and rotary control panel (360°) along machine bed (except L1600).
- Touch screen 19".
- Chip Conveyor with integrated coolant tank.
- External coolant system around the spindle.
- Programmable central lubrication system.
- Climatised electrical cabinet.
- Machine levelling elements.
- Informative cartel in black methacrylate.
- SMART POINT machine data monitoring system.

OPTIONAL ITEMS

- Coolant through spindle.
- NSM software and division wall of working areas.
- Transport cart for the division wall.
- ATC magazines up to 255 tools.
- Pick up stations integrated in the machine to hold special tools and angular heads.
- Special tool magazines up to 400 positions managed by arm robot.
- Tool measuring and touch systems.
- C axis integrated rotary tables up to $\varnothing 1200$ mm.
- Big diameter rotary tables up to $\varnothing 2000$ mm together with the fix table.
- Bolt on rotary tables to be used either in horizontal or vertical axis.
- Special working table configurations: moving tables, trunnion fixtures...
- Steam and mist aspiration system.
- Spray and air guns.
- "Comfort" pack: Sliding access stairway along the longitudinal travel with supports for air and water guns.
- "Illumination" pack: LED lights with acoustic signal indicating the state of the machine, integrated into the sides.
- 3 light tower with acoustic signal indicating the state of the machine.
- Camera settings and display mode.
- CNC control with touch screen up to 24".
- Advanced HMI.
- Portable electronic hand-wheel with support in the control pannel.